

CAPTURE[®] a better viewing experience.

- Advanced Optical Projection Surface for Large Venues
- Fully Visible Images in High Ambient Light
- Superior Contrast Levels
- Reduced Projector Power — **UP TO 50%**
- Extremely Durable and Vandal Resistant
- Ideal Applications:
 - Houses of Worship
 - Digital Signage
 - Staging & Rental
 - Arena & Concourse
 - Lobby & Public Space
 - In Place of Rear Projection
- The Indoor LED and Video Wall Alternative:
 - Dramatically Lower Cost
 - Reduced Weight
 - Minimized Maintenance



CAPTURE[®] G5

CAPTURE[®] is an innovative optical front projection surface that efficiently captures and uniformly distributes projected light to deliver brilliant images in high ambient lighting conditions with unprecedented gains of up to 5. Not only do CAPTURE Displays cure the traditional screen concerns of ambient lighting, they also overcome the physical weight, power requirements and pricing issues of large electronic displays. CAPTURE Displays have been installed in airports, shopping malls, and religious institutions, among others. Call **417.237.0905** or visit capturedisplays.com to learn more.

CAPTURE[®]
Optical Brilliance. Captured.

CAPTURE G5

- High ambient light projection display for large venues
- Recommended minimum viewing distance of 25 feet
- Optical-grade surface
- Rigid contoured structure that maximizes image performance**
- Sizes ≤ 100":
 - Seamless single-piece construction
 - VESA 200 mm mounting pattern
 - Use standard wall mount rated for proper weight (not included)
 - Individual screen ships complete in one box
- Sizes 101" – 150":
 - Single-piece construction with minimal seams
 - VESA 400 mm mounting pattern
 - Individual screen ships complete in one box
- Sizes > 150":
 - Multi-piece construction with less than 2 mm seams
 - Use C200 mount (sold separately)
 - Field assembly required
 - Parts ship in multiple boxes
- Options:
 - Trim – Extruded rigid PVC with black velvet covering. Add 4" to image area height and width for trim
 - Additional Sizes – Custom formats and sizes available upon request

WALL STAND-OFF

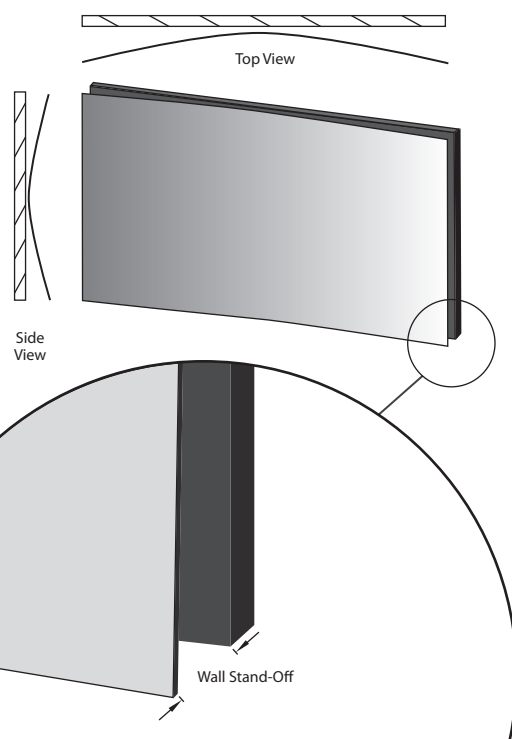

CAPTURE G5 vs. the Competition

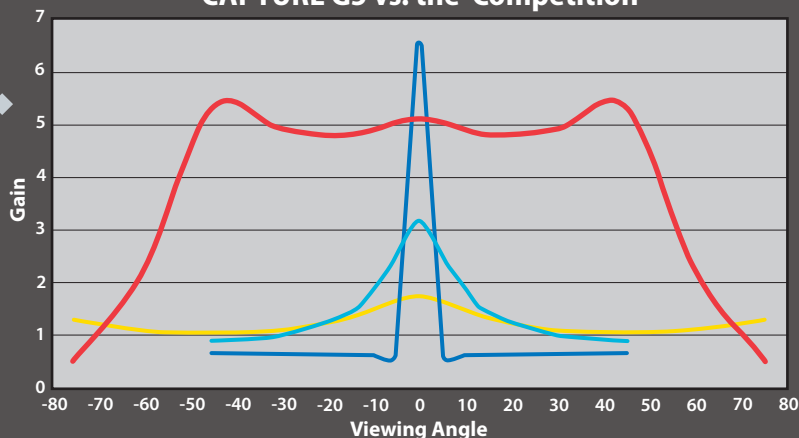

— CAPTURE G5
 — Competitor matte high-gain — Competitor 2.8 gain — Competitor 4.5 gain

SPECIFICATIONS

G5 SURFACE

Viewing Angles	Gain
90° h x 25° v	5

DIMENSIONS

4:3 STANDARD

Product Number	Nominal Diagonal (in)	Image Area* H x W (in)	Wall Stand-Off** (in)		Net Weight (lbs)
			32' Radius	64' Radius	
C100S	100	60 x 80	5	3	67
C119S	119	72 x 95	6	4	92
C145S	145	87 x 116	8	5	132
C163S	163	98 x 130	n/a	10	526***

16:9 HDTV

Product Number	Nominal Diagonal (in)	Image Area* H x W (in)	Wall Stand-Off** (in)		Net Weight (lbs)
			32' Radius	64' Radius	
C100HD	100	49 x 87	5	3	60
C109HD	109	53 x 95	5	3	70
C119HD	119	58 x 104	6	4	82
C133HD	133	65 x 116	7	4	101
C150HD	150	74 x 131	9	5	127
C200HD	200	98 x 174	n/a	12	580***

16:10 WIDE

Product Number	Nominal Diagonal (in)	Image Area* H x W (in)	Wall Stand-Off** (in)		Net Weight (lbs)
			32' Radius	64' Radius	
C112W	112	59 x 95	6	4	74
C137W	137	73 x 116	8	5	106
C150W	150	79 x 127	9	5	133
C185W	185	98 x 156	n/a	11	559***